

8 7 6 5 4 3 2 1

D

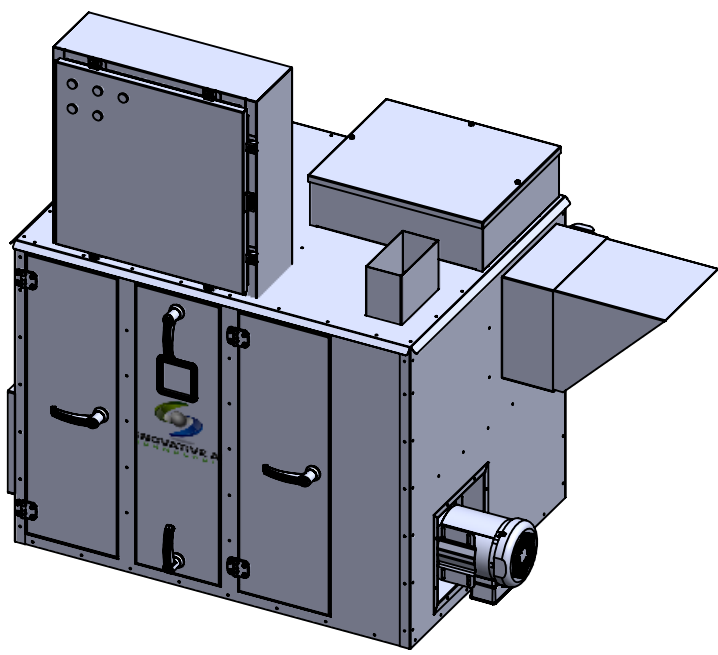

C

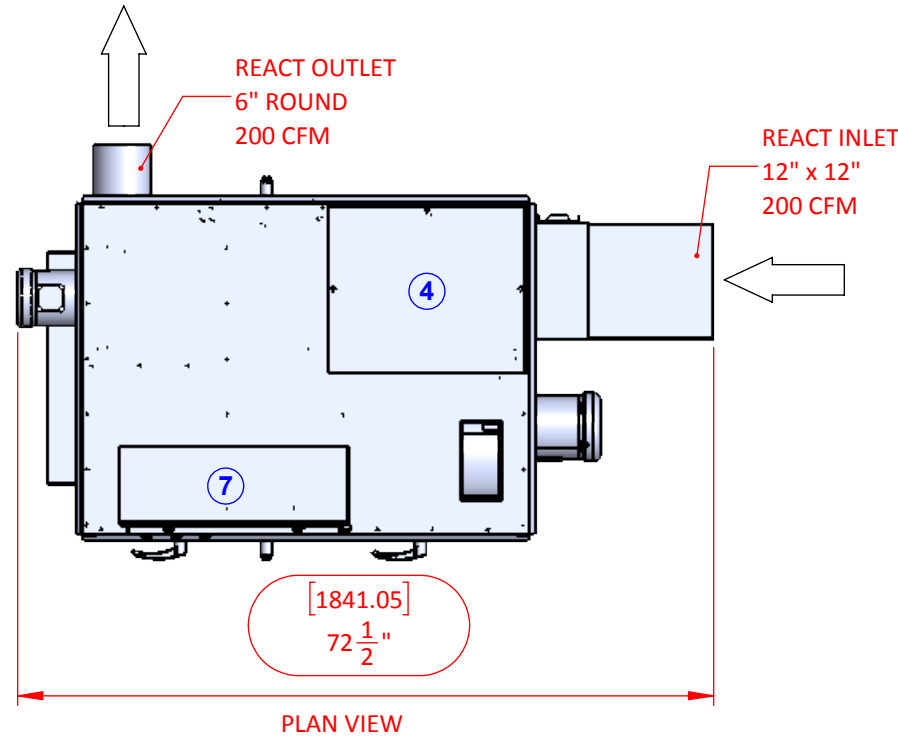

B

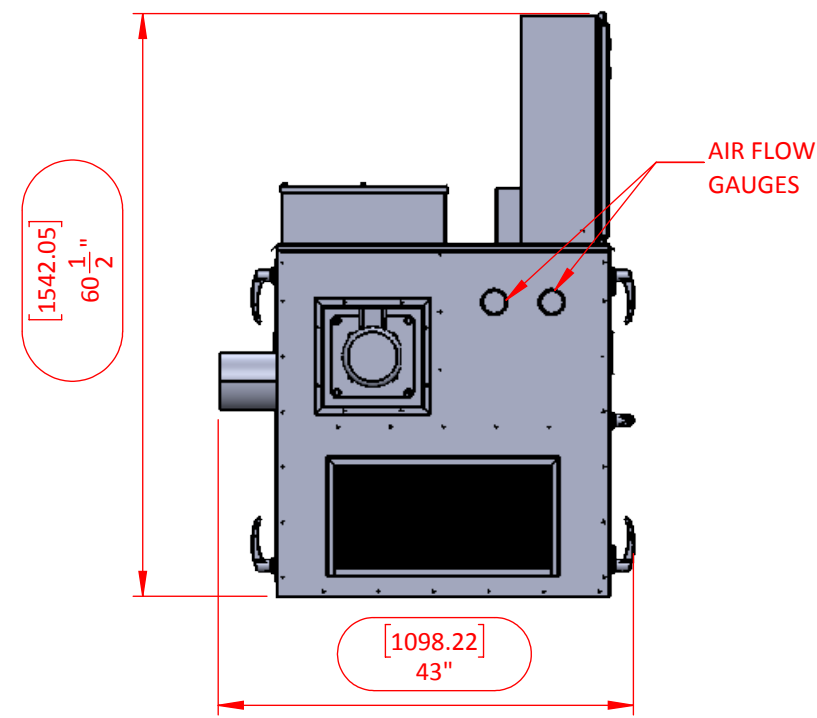

A

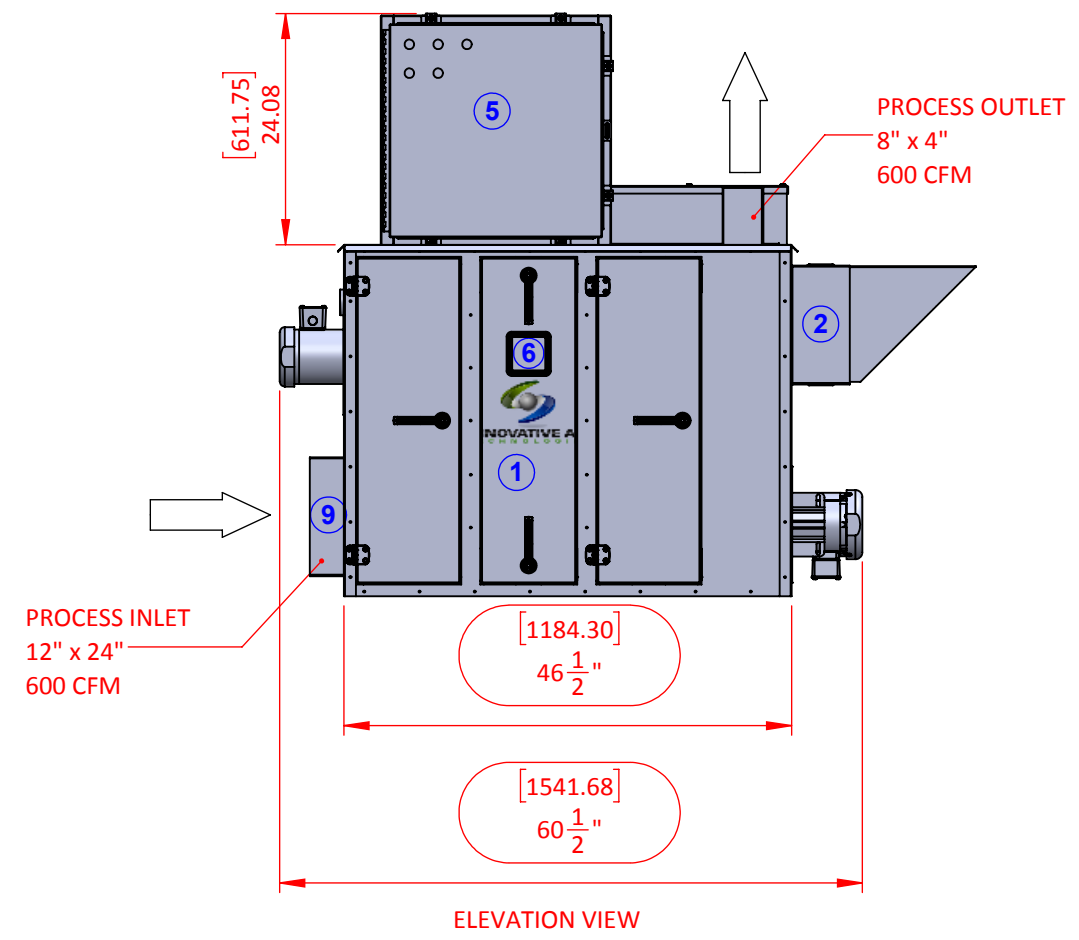

Item	Description
1	IAT-600RE Desiccant Dehumidifier
2	React Inlet Filter - 12" x 12" x 2" (30%)
3	React Air Blower - 6-1/4" x 1 1/2", 2.8" TSP 3450 RPM, with a .5 HP TEFC motor
4	React Heater, 13 Kwh total (staged)
5	Electrical Control Box, 24" x 24" x 8", NEMA 12
6	Rotor Observation Window
7	Power Input, top right of control box
8	Process Air Blower - 7" x 2 1/2", 3.4" TSP with 1 HP TEFC motor
9	Process Inlet Filter - 12" x 24" x 2" (30%)
Notes	
1	System Performance - 600 CFM
2	Allow 36" in the front, 36 in the back, and 6" on the sides of the unit for clearances for service
3	React Outlet Blower is equipped with air volume damper
4	All External ductwork must be air and vapor tight
5	Fan Outlets must be transitioned to larger duct size
6	Total weight of unit - approximately 750 Lbs.
7	-

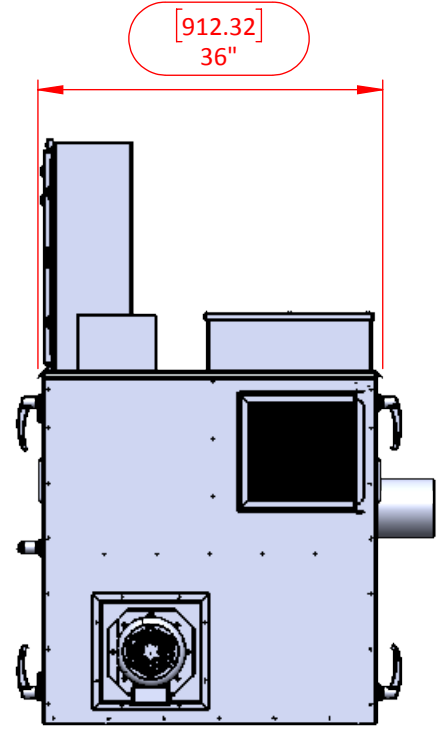

UNLESS OTHERWISE SPECIFIED DIMENSIONS ARE IN INCHES TOLERANCES: FRACTIONAL: 1/32 ANGULAR: MACH ± BEND ± 1 TWO PLACE DECIMAL ± .030 THREE PLACE DECIMAL ± .015 INTERPRET GD&T PER:		PROPRIETARY AND CONFIDENTIAL THE INFORMATION CONTAINED IN THIS DRAWING IS THE SOLE PROPERTY OF INNOVATIVE AIR TECHNOLOGIES, INC. ANY PARTIAL OR COMPLETE REPRODUCTION WITHOUT THE WRITTEN PERMISSION OF INNOVATIVE AIR TECHNOLOGIES, INC. IS PROHIBITED.			
MATERIAL: WEIGHT: 738.17 lbs.		APPROVALS	NAME	DATE	TITLE: IAT-600RE UNIT OUTLINE
FINISH:		DRAWN	GR	5/17/2017	FOR: CUSTOMER NAME
COMMENTS:		CHECKED			SIZE: DWG. NO. REV.
		ENG APPR.			B 600 IAT DH UNIT OUTLINE
		MFG APPR.			SCALE: 1:20 SHEET 1 OF 1
		Q.A.			

8 7 6 5 4 3 2 1