

SPECIFICATIONS

PROCESS AIR FLOW	75 CFM
REACTIVATION AIR FLOW	25 CFM
REACTIVATION HEAT	3,240 BTUH
TOTAL POWER CONSUMPTION	1,400 WATTS
TOTAL WEIGHT	85 LBS
DESICCANT ROTOR	SILICA GEL

NOTES

1. Case is all stainless steel construction
2. React & Process Outlets equipped with air volume dampers
3. 30% Replaceable Filter
4. Allow a minimum of 5% make up air on Process Inlet
5. Silica gel desiccant is embedded in rotating wheel

*** TYPICAL PERFORMANCE ***

- 75 DEG. F @ 50%RH - 2.3 LBS/HR.
- 75 DEG. F @ 30%RH - 1.5 LBS/HR.
- 75 DEG. F @ 10%RH - 0.5 LBS/HR.

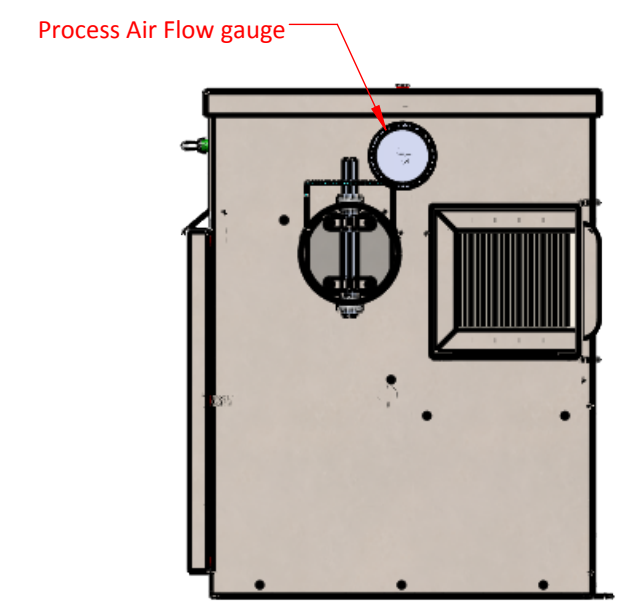
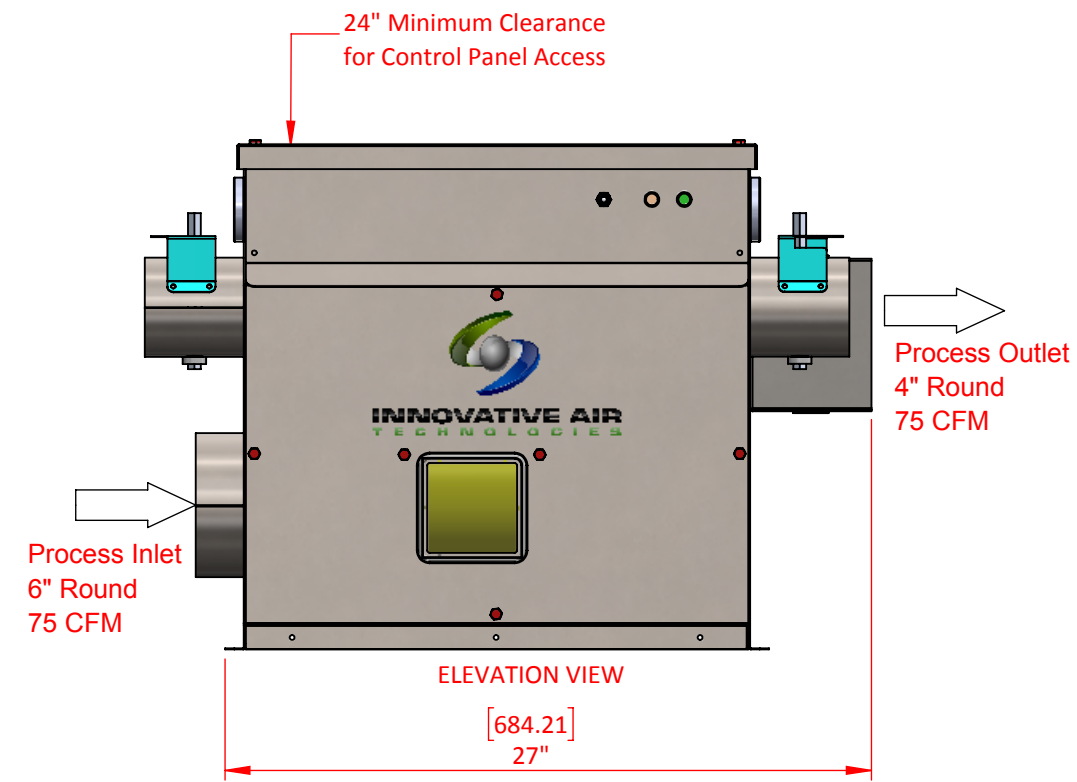
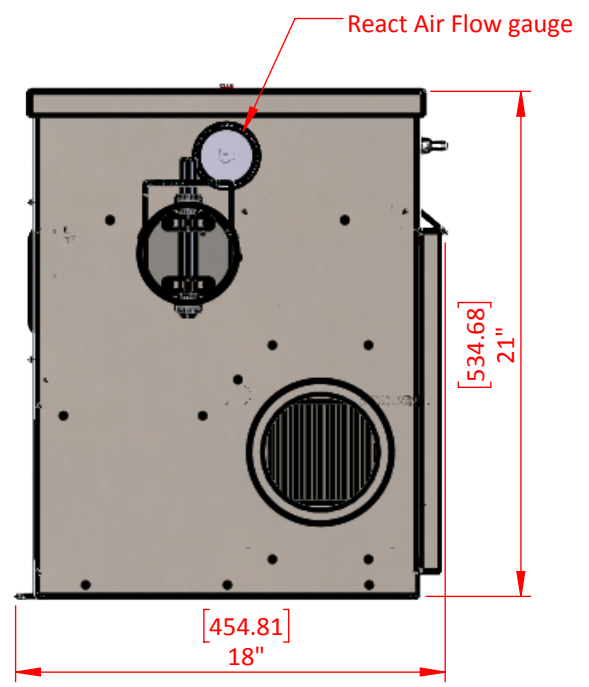
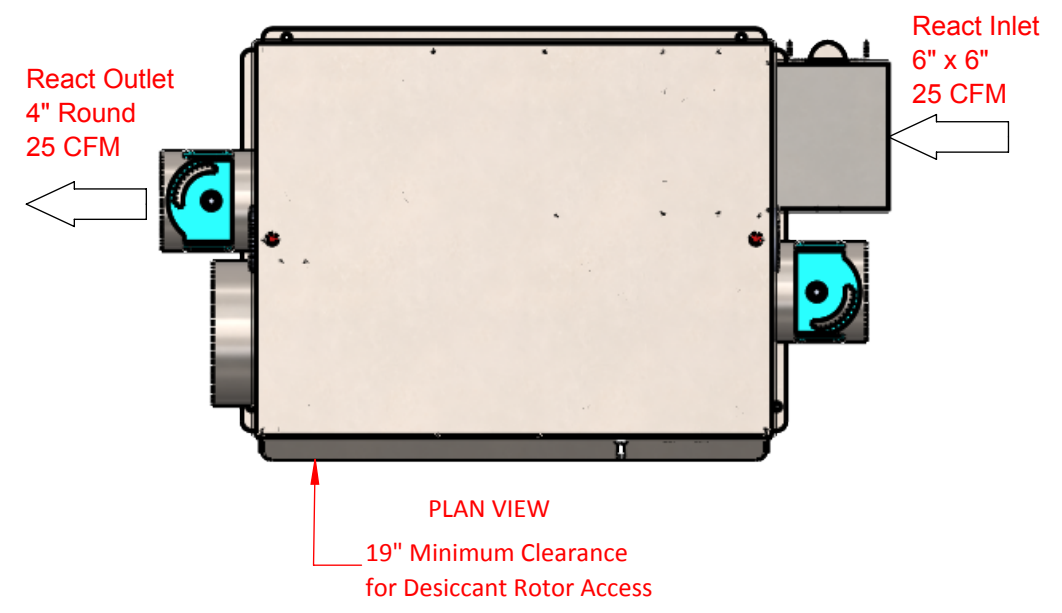
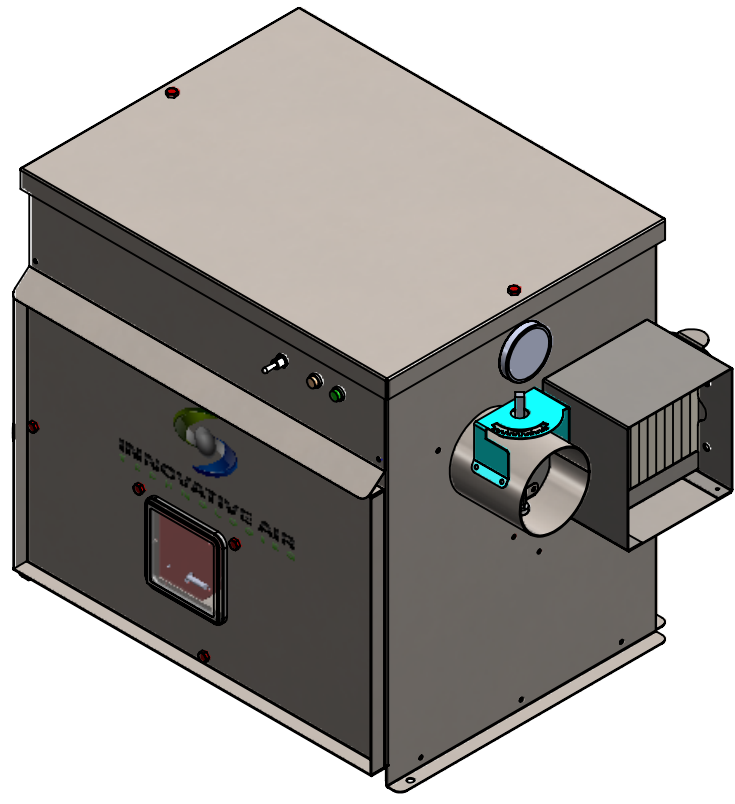

UNLESS OTHERWISE SPECIFIED DIMENSIONS ARE IN INCHES TOLERANCES: FRACTIONAL: 1/32 ANGULAR: MACH ± BEND ± 1 TWO PLACE DECIMAL ± .030 THREE PLACE DECIMAL ± .015 INTERPRET GD&T PER:		PROPRIETARY AND CONFIDENTIAL THE INFORMATION CONTAINED IN THIS DRAWING IS THE SOLE PROPERTY OF INNOVATIVE AIR TECHNOLOGIES, INC. ANY PARTIAL OR COMPLETE REPRODUCTION WITHOUT THE WRITTEN PERMISSION OF INNOVATIVE AIR TECHNOLOGIES, INC. IS PROHIBITED.			
MATERIAL:		APPROVALS	NAME	DATE	TITLE
WEIGHT: 86 lbs.		DRAWN	GR	6/23/2017	FOR: CUSTOMER NAME
FINISH:		CHECKED			SIZE DWG. NO. REV.
COMMENTS:		ENG APPR.			B IAT-75RE UNIT OUTLINE
		MFG APPR.			SCALE: 1:8 SHEET 1 OF 1
		Q.A.			